

Specifications

SMART Board® interactive whiteboard

Model X885/885-SMP

Physical specifications

Size	78 1/2" W × 53 3/8" H × 6 1/2" D (199.4 cm × 135.6 cm × 16.5 cm)
Active screen area (maximum interactive projected image)	74" W × 46 1/4" H (188 cm × 117.5 cm) 87" (221 cm) diagonal 16:10 aspect ratio
Weight	60 lb. (27.2 kg)
Shipping size	
1 unit	4 3/8" W × 56 3/4" H × 88" D (11.1 cm × 144.1 cm × 223.5 cm)
10 units on a pallet	44 1/4" W × 92 5/8" H × 56 3/4" D (112.4 cm × 235.3 cm × 144.1 cm)
Shipping weight	
1 unit	90 lb. (40.8 kg)
10 units on a pallet	920 lb. (417 kg)

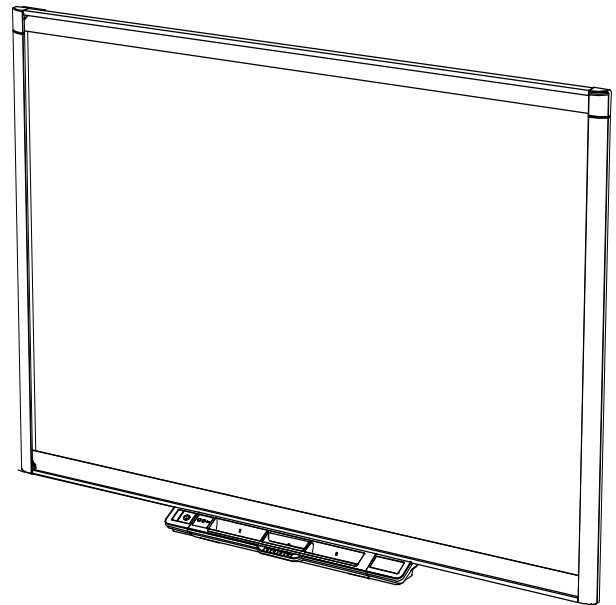

All dimensions +/- 1/8" (0.3 cm). All weights +/- 2 lb. (0.9 kg).

Extraordinary made simple®

SMART®

SPECIFICATIONS

SMART Board interactive whiteboard – Model X885/885-SMP

Standard features

Software The following software options are available:

X885 SMART Notebook™ collaborative learning software including SMART Product Drivers
OR

885-SMP SMART Meeting Pro™ software including SMART Product Drivers

Touch and gestures Perform mouse functions with your finger, and write and erase digital ink with a pen tray pen or the eraser. The Object Awareness feature enables you to pick up a pen, and then write, select or erase without replacing the pen. This interactive whiteboard also features gesture capability, providing a natural and flexible way to interact with content.

Multitouch capabilities Users can interact with the interactive whiteboard using the included pens or other objects, or by using their fingers to write and perform gestures.

The following multitouch capabilities are available:

System	Multitouch capability
X885	Support for four simultaneous touches enables up to four users to interact with the interactive whiteboard.
885-SMP	Support for two simultaneous touches enables up to two users to interact with the interactive whiteboard.

SMART Ink™ Smooths out the appearance of the digital ink, improving the legibility of your handwriting. The ink becomes an object you can move and manipulate.

Lockable pen option Hold down a pen color button on the pen tray until its light flashes to lock the interactive whiteboard in pen mode. In this mode you can use any device as a pen. Early education students and students with special needs can use an object like a tennis ball to write more easily on the surface.

Pen tray Optical sensors in the pen tray detect when you lift a pen or eraser from the tray. Color buttons on the pen tray enable you to select pen color.

The following pen tray features are available:

System	Features
X885	Removable end caps for optional accessories
885-SMP	SBX800 CAT5-XT USB extender

Pen and eraser Two ergonomic pens with a comfort grip and a rectangular eraser

Resolution Touch resolution is approximately 4000 × 4000.

SPECIFICATIONS

SMART Board interactive whiteboard – Model X885/885-SMP

Screen surface The hard-coated steel surface is durable, optimized for projection, compatible with dry-erase markers and easily cleaned.

Digitizing technology Four-camera DViT® (Digital Vision Touch) technology

Frame finish Two-tone gray (Dark gray approximates PANTONE® Charcoal Gray 18-0601 TPX. Light gray approximates PANTONE Cool Gray 6C.)

Wall-mount bracket Two 32" (81.3 cm) wide brackets with 10 screws and toggle bolt anchors to support a wall-mounted interactive whiteboard

Computer connection The following computer connection methods are available:

System	Connection method
X885	16' (5 m) USB 2.0 cable to room computer
885-SMP	An SBX800 CAT5-XT USB extender is included and enables you to connect your interactive whiteboard pen tray to a guest computer up to 50' (15 m) away using a Cat 5, Cat 5e or Cat 6 cable (not included). For more information, see smarttech.com/kb/154489 .

Power connection 6' (1.8 m) power cable

Power requirements Power consumption is less than 7 W (100V to 240V AC, 50/60 Hz, 5V DC 2.0A)

Environmental compliance EU REACH, RoHS, WEEE and Packaging, US Packaging and China EIP

Regulatory certification CE, CSA (U.S./Canada) and FCC

i NOTE

A digital projector isn't included with this model of SMART Board interactive whiteboard. To take advantage of all interactive features, you must integrate a digital projector.

Warranty

Interactive whiteboard Your interactive whiteboard has a two-year limited equipment warranty or a five-year limited equipment warranty upon registration. See warranty documents for details.

Accessories Your accessories have a one-year warranty.

SPECIFICATIONS

SMART Board interactive whiteboard – Model X885/885-SMP

Storage and operating specifications

Storage	-40°F to 120°F (-40°C to 50°C)
Operation	41°F to 95°F (5°C to 35°C) with up to 80% humidity, non-condensing

Computer requirements

You need to connect a computer to your interactive whiteboard. Choose one of the following options:

X885	A computer or laptop with either a Windows® operating system or Mac operating system software and SMART Notebook software installed. For a complete list of computer requirements, go to smarttech.com/downloads and browse to the latest SMART Notebook release notes applicable to your operating system.
885-SMP	A computer or laptop with a Windows operating system and SMART Meeting Pro software installed. For a complete list of computer requirements, go to smarttech.com/downloads and browse to the latest SMART Meeting Pro release notes applicable to your operating system.

i NOTE

If the computer or laptop doesn't have SMART Meeting Pro software installed, it can be connected to the interactive display using the SMART GoWire™ auto-launch cable included with this product. For a complete list of computer requirements, go to smarttech.com/downloads and browse to the latest SMART GoWire cable release notes applicable to your operating system.

SMART order numbers

SBX885	87" (221 cm) diagonal SMART Board interactive whiteboard. Includes a SMART Notebook software installation DVD.
SB885-SMP	87" (221 cm) diagonal SMART Board interactive whiteboard. Includes a SMART GoWire cable containing SMART Meeting Pro and SMART Bridgit® software. An SBX800 CAT5-XT USB extender is also included (see <i>Computer connection</i>).

SPECIFICATIONS

SMART Board interactive whiteboard – Model X885/885-SMP

Physical dimensions

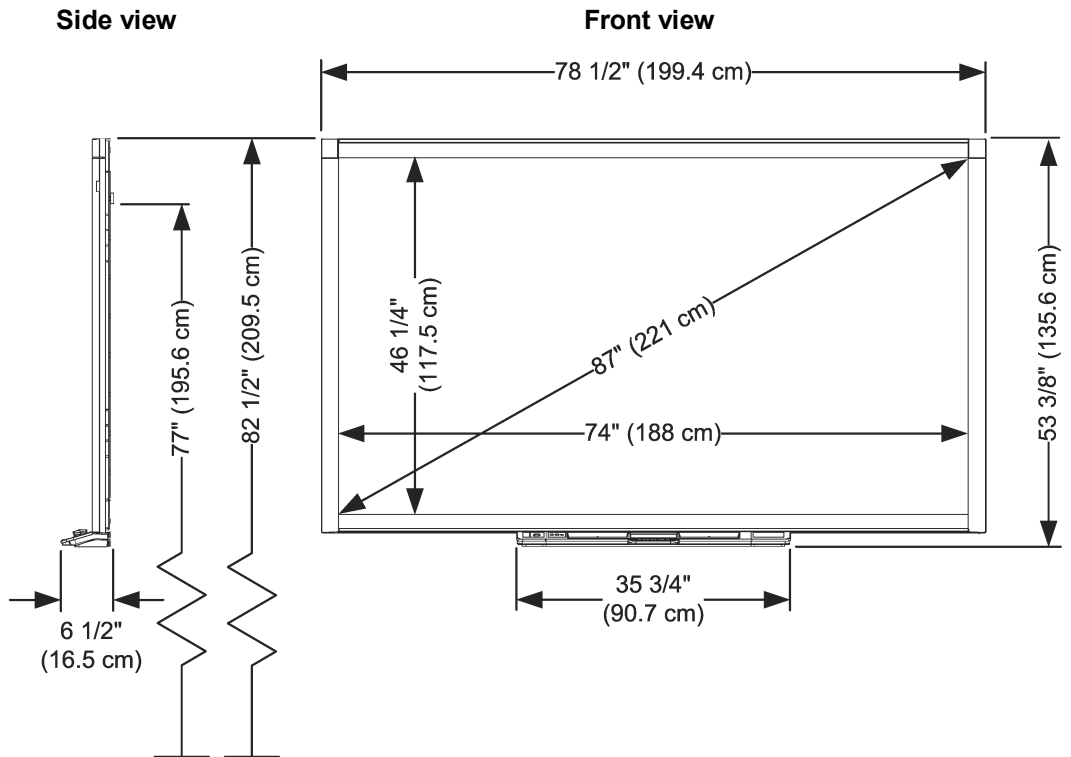

Leave at least 5/8" (1.6 cm) headroom to wall mount the SB885. The distance from the bottom of the wall mount bracket to the top of an installed interactive whiteboard is 6 1/8" (15.6 cm)

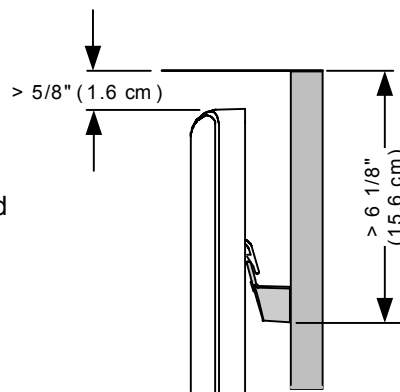

smarttech.com/support
smarttech.com/contactsupport

© 2010–2012 SMART Technologies ULC. All rights reserved. SMART Board, SMART Notebook, SMART GoWire, SMART Meeting Pro, SMART Bridgit, SMART Ink, DVIT smarttech, the SMART logo and all SMART taglines are trademarks or registered trademarks of SMART Technologies ULC in the U.S. and/or other countries. All third-party product and company names may be trademarks of their respective owners. One or more of the following patents: US6320597; US6326954; US6540366; US6563491; US6741267; US6803906; US6829372; US6919880; US6954197; US7151533; US7184030; US7236162; US7411575; US7532206; US7619617; US7643006; US7692625; US7757001; US7880720; USD612396; USD616462; USD617332; USD635189 and USD636183. Other patents pending. Contents are subject to change without notice. 07/2012.