

Specifications

Wireless connection for SMART Board™ 800 series interactive whiteboards

Physical specifications

Size	
USB interface	1" W × 3 3/8" H × 3/8" D (2.4 cm × 8.5 cm × 1 cm)
Wireless adapter	5 1/8" W × 2 1/8" H × 5" D (13 cm × 5.5 cm × 12.8 cm)
Weight	
USB interface	less than 1 oz. (13 g)
Wireless adapter	2 oz. (50 g)
Shipping weight	10 oz. (280 g)
Shipping size	6 5/8" W × 5 1/8" H × 2 5/8" D (17 cm × 13 cm × 6.7 cm)

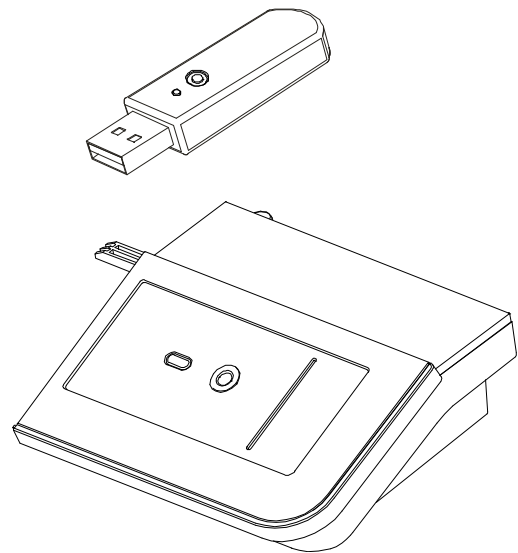

Standard features

Host interface	USB interface connects to the computer. This host interface is a SMART proprietary USB HID and USB audio device that connects to the wireless adapter. It is <i>not</i> a generic Bluetooth® device.
Interactive whiteboard interface	Wireless adapter connects to the interactive whiteboard

Software/firmware	SMART software updates are available at smarttech.com/downloads . For information on how to update SMART firmware, see smarttech.com/kb/155533 .
Technology	Bluetooth® 2.1+EDR industry-standard wireless technology, Bluetooth Qualification Design ID (QDID) B017480
Security	56-bit encryption support. Bluetooth security is built into the paired components.
Radio frequency	2.4 GHz ISM band
FHSS	Frequency Hopping Spread Spectrum at up to 1,600 hops/second among 79 channels spaced 1 MHz apart
Transmission power	Class 2, 2.5 mW, 4 dBm with a typical range of 33' (10 m)
Receiver sensitivity	-80 dBm at 1e-5 BER (typical)
Audio delay	75ms (maximum)
Antenna	Integrated antenna
Status indicator lights	Status lights on both components indicate the link status.
Configuration	Plug and play (no additional software required)
Environmental compliance	EU RoHS, EU WEEE, Packaging, US CPSIA, EIP
Regulatory certification	Bluetooth, CE, C-Tick, FCC, IC, TRA, CSA
Warranty	One-year limited equipment warranty upon registration. See warranty document for details.
Storage and operating specifications	
Storage	-40°F to 120°F (-40°C to 50°C)
Operating	41°F to 95°F (5°C to 35°C) with up to 80% humidity, non-condensing
SMART order number	
WC8	Wireless Connection for SMART Board™ 800 series interactive whiteboards

Physical dimensions

Wireless adapter

Top view

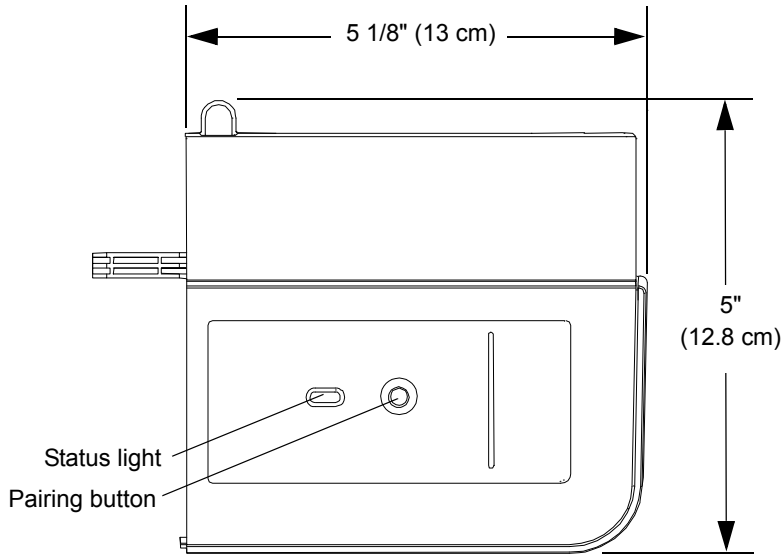

USB interface

Front view

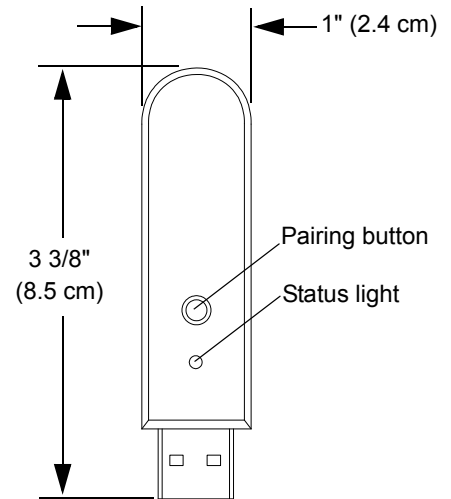

Front view

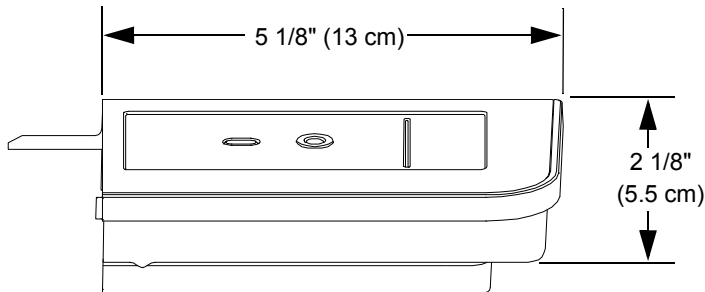

Side view

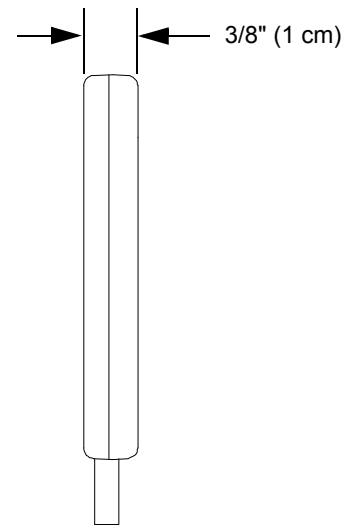

Side view

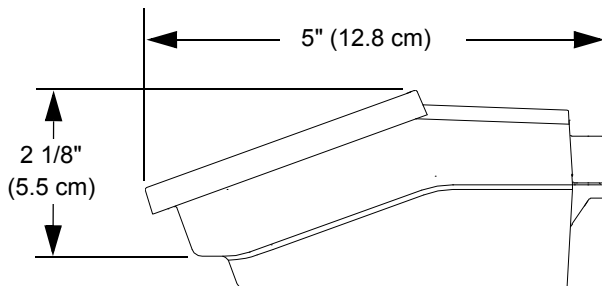

www.smarttech.com/support www.smarttech.com/contactsupport
Support +1.403.228.5940 or Toll Free 1.866.518.6791 (U.S./Canada)

SMARTTM

© 2011 SMART Technologies ULC. All rights reserved. SMART Board, the SMART logo and smarttech are trademarks or registered trademarks of SMART Technologies ULC in the U.S. and/or other countries. The Bluetooth word mark is a registered trademark and is owned by the Bluetooth SIG, Inc. and any use of such marks by SMART Technologies ULC is under license. All other third-party product and company names may be trademarks of their respective owners. Patents pending. Contents are subject to change without notice. 01/2011.