

Specifications

SMART Board® interactive whiteboard system

Model SB480i6

Overview

Your SMART Board® 480i6 interactive whiteboard system combines the use of a SMART Board 480 series interactive whiteboard and a the SMART UF70 projector along with other accessories and optional equipment.

The SMART UF70 projector provides an ultra-bright high resolution image on a short boom delivering high definition, high performance interactivity that is virtually shadow-free and glare-free. The SB480 series interactive whiteboard is a durable single-user system. You can do everything you can do at your computer—open and close applications, meet with others, create new documents or edit existing ones, visit websites, play and manipulate video clips and more— just by touching the interactive surface.

The SB480i6 system supports video and audio from a variety of devices, including DVD and Blu-ray™ players, document cameras, and other high-definition sources, and is displayed on the interactive screen. All HDMI 1.4 inputs are HDCP compliant.

See smarttech.com for more information on this product.

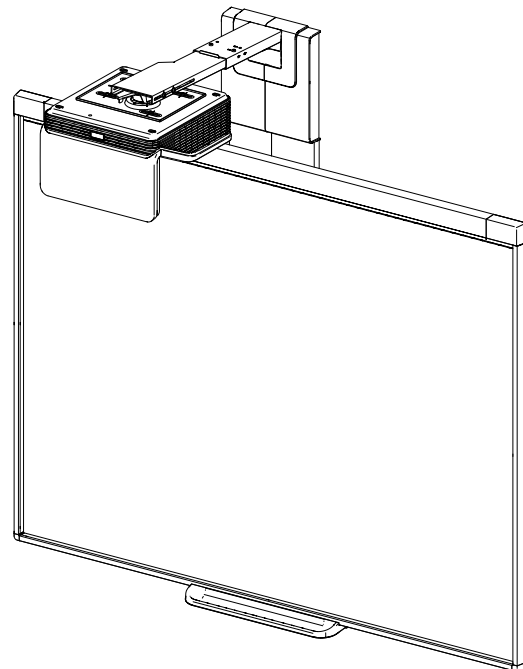

Dimensions and weights*

Dimensions

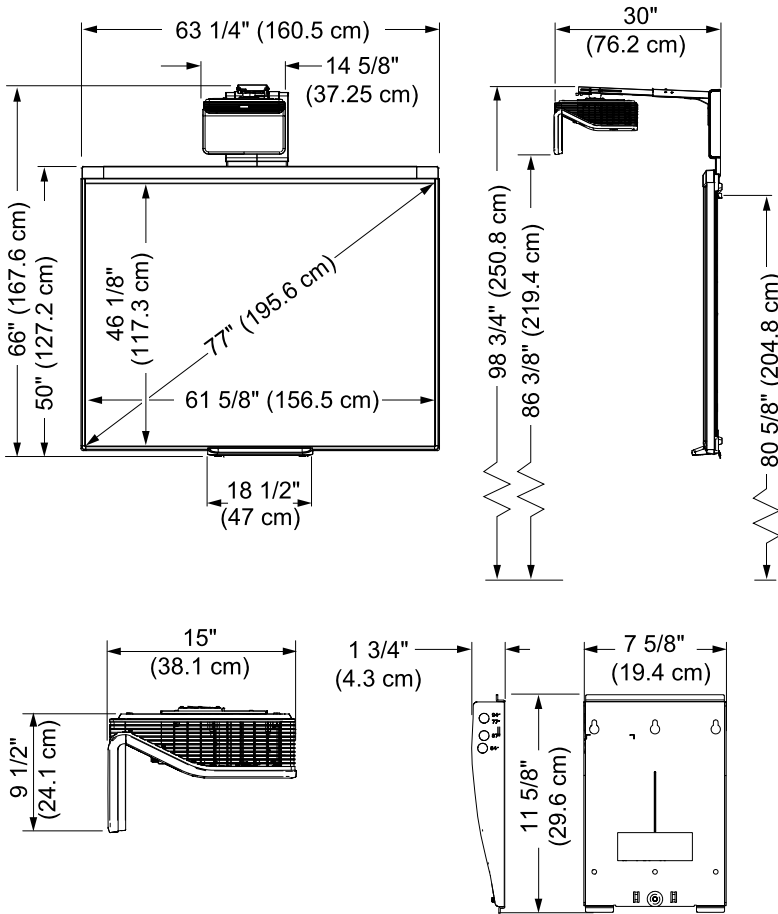

SMART Board 480 interactive whiteboard

Weight

51 lb. (23.2 kg)

Shipping dimensions

70" W × 53 1/2" H × 4 1/2" D
(178 cm W × 136 cm H × 11 cm D)

Shipping weight

63 lb. 2 oz. (28.7 kg)

SMART UF70 projector

Weight (projector only)

16 lb. 11 oz. (7.6 kg)

Weight (projector and boom)

28 lb. 6 oz. (12.9 kg)

Shipping weight

35 lb. 13 oz. (16.2 kg)

Projector dimensions

14 5/8" W × 9 1/2" H × 30" D
(37.1 cm × 24.1 cm × 76.2 cm)

Shipping dimensions

20" W × 15 1/2" H × 24" D
(50.8 cm × 39.4 cm × 61 cm)

Remote Control

Dimensions

1 5/8" W × 3 3/8" H × 1/4" D
(4.1 cm × 8.6 cm × 0.6 cm)

*All dimensions ± 1/8" (0.3 cm). All weights ± 2 lb. (0.9 kg).

Hardware

Projector

Brightness (standard)	3000 lumens 230 W mode at a CCT of 6500 K by the IEC method
Brightness (economy)	2250 lumens 190 W mode. at a CCT of 6500 K by the IEC method
Native resolution	XGA 1024 × 768
Aspect ratio	4:3 with support for 16:9, 16:10 and 5:4 with scaling.
Throw ratio	Short throw 0.43:1 ratio
Throw distance	27" (68.4 cm)
Display technology	The projection engine uses DLP® technology by Texas Instruments™, providing BrilliantColor™ performance and quality Gamma 2.2 correction with Bright Room, Dark Room, sRGB, User and SMART Presentation modes.
Lamp life	3000 hours in Standard 230 W mode. 4000 hours in Economy 190 W mode.
Integrated loud speaker	9 W rms
Projector noise	32 dBA standard fan speed. 37 dBA high speed fan speed.
Contrast ratio (typical)	2900:1
Video system compatibility	HDTV (720p and 1080p) video system compatibility and HD Ready (HDMI technology and 720p) available, NTSC, NTSC 4:43, PAL, PAL-N, PAL-M and SECAM (480i/p and 576i/p)
Video interface compatibility	HDCP compliant HDMI, Composite, VESA® RGB with additional interface support for Component YPbPr and Component YCbCr inputs with the proper adapters (not included)
Horizontal frequency	15kHz–72 kHz
Vertical frequency	15Hz–75 Hz
Clock frequency	165 Mhz
External management	Infrared remote control RS-232 control port, internal web page, Crestron® RoomView® management via Ethernet



Interactive whiteboard

Touch resolution	32767 × 32767
Touch	Two-camera one-user system
Digitizing technology	DViT® (Digital Vision Touch) technology
Pen tray	Includes a pen tray pen.
Accessories	One ergonomic pen with comfort grip

SPECIFICATIONS

SMART BOARD® INTERACTIVE WHITEBOARD SYSTEM – MODEL SB480i6

Included cables and hardware SB480i6	14' 9" (4.5 m) power cable Infrared remote control 16' 5" (5 m) USB cable
Theft protection	The projector system features an optional padlocked ring to prevent theft. The Kensington® security slot can affix the system to a wall as a visual and physical theft deterrent.

Connectors

Projector connectors	3.5 mm phone jack audio input 3.5 mm phone jack audio output DB15F RGB VGA video input (VGA In) DB15F RGB VGA video input (VGA Out) DB9F RS-232 control port HDMI 1.4 input Power (100V–240V AC at 50 Hz–60 Hz) USB-B port (for service use only) RJ45 Ethernet connector 7-pin mini-DIN for ECP data 4-pin mini-DIN 5V/2A output for ECP USB HUB/switch power RCA analog audio and composite video (red, white and yellow) Microphone 3.5 mm
-----------------------------	---

Computer requirements

SB480i6	Windows® operating system or Mac operating system software and SMART Notebook® collaborative learning software installed. For a complete list of computer requirements, go to smarttech.com/downloads and browse to the latest SMART Notebook software release notes applicable to your operating system.
----------------	--

Storage and operating requirements

Power requirements and consumption	100V–240V AC at 50 Hz–60 Hz
Full mode	360 W
ECO mode	360 W
Standby mode	0.5 W
Operating temperature	
Interactive whiteboard	41°F to 95°F (5°C to 35°C) from 0' to 6000' (0 m to 1800 m) 41°F to 86°F (5°C to 30°C) from 6000' to 9800' (1800 m to 3000 m)
Projector	Standard speed: 41°F to 95°F (5°C to 35°C) from 0' to 6000' (0 m to 1800 m) High speed: 41°F to 86°F (5°C to 30°C) from 6000' to 6800' (1800 m to 2100 m)
Storage temperature	-4°F (-20°C) to 122°F (50°C)
Humidity	Up to 80% storage relative humidity, non-condensing Up to 80% operating relative humidity, non-condensing

Certification and compliance

Regulatory certification CE, CB, CCC, CE, C-Tick, FCC, KC, GOST-R, NOM, PSB, PSE, TUV-GS, UL/CSA(U.S./Canada) and VCCI

Environmental compliance

China	EIP
European Union	REACH, RoHS, WEEE, Battery, Packaging and ErP Standby
U.S.	Packaging and Conflict Minerals

Warranty

Interactive whiteboard Two-year limited equipment warranty

Projector Three-year limited equipment warranty

Projector lamp 1000-hour/one-year warranty

Purchasing information

Order numbers

SB480i6	77" (195.4 cm) diagonal SMART Board interactive whiteboard with a SMART UF70 projector system. Includes a SMART Notebook software installation DVD.
1020991	Replacement lamp for SMART UF70 and UF70w projectors
1013576	Projector hardware kit (see smarttech.com/kb/160505)

Optional extended warranty

(EWY1-UF70)	SMART UF70 projector one year warranty extension (available at time of projector purchase only)
(EWY2-UF70)	SMART UF70 projector two year warranty extension (available at time of projector purchase only)

Optional accessories See smarttech.com/accessories

smarttech.com/support

smarttech.com/contactsupport

© 2013–2014 SMART Technologies ULC. All rights reserved. SMART Board, smarttech, the SMART logo and all SMART taglines are trademarks or registered trademarks of SMART Technologies ULC in the U.S. and/or other countries. All third-party product and company names may be trademarks of their respective owners. This product and/or use thereof covered by one or more of the following U.S. patents. www.smarttech.com/patents. Contents are subject to change without notice. 11/2014.