

Product Dimensions:

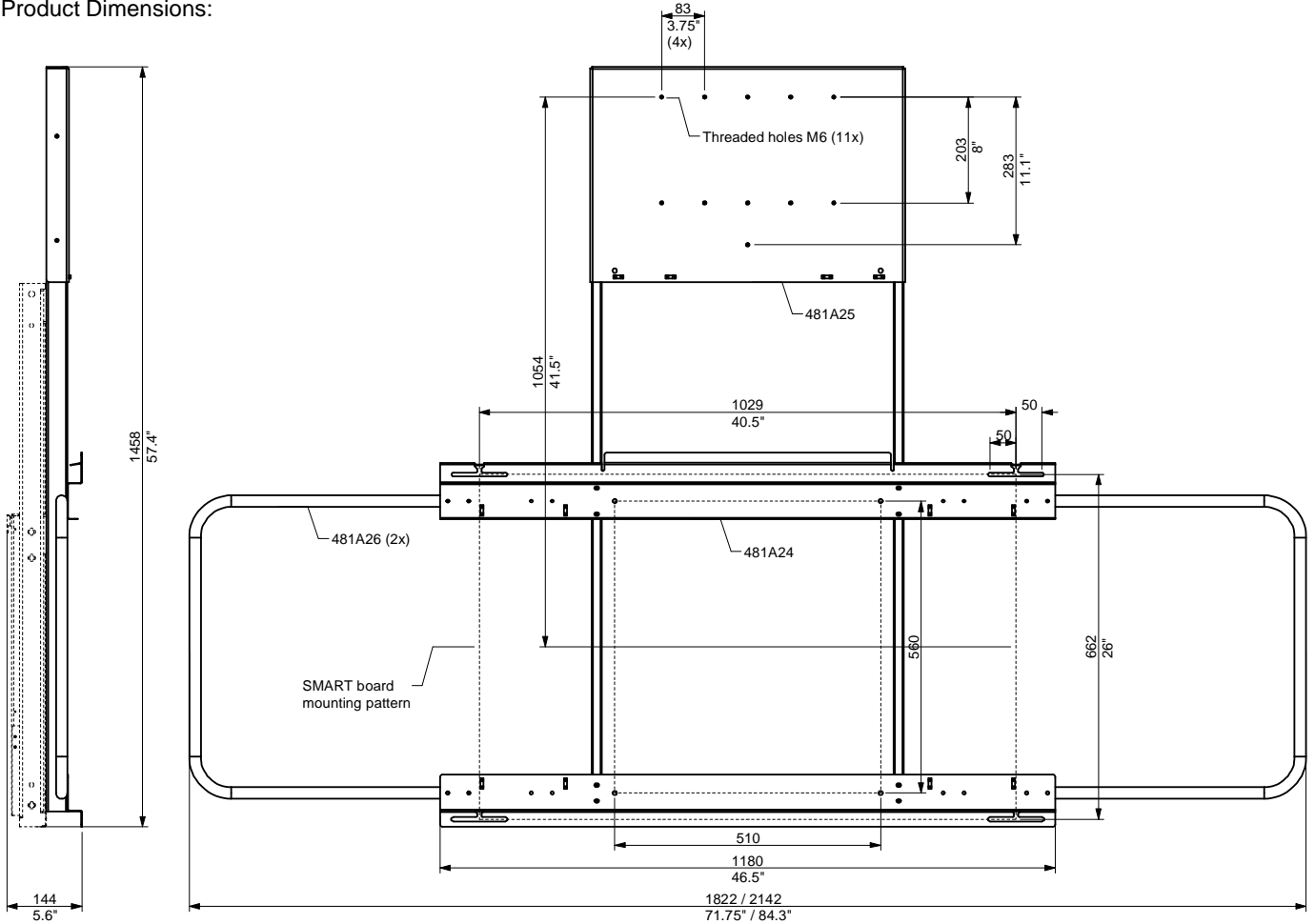

Mounting accessories for SMART® boards and projectors for Balancebox® 400H		Weight kg	Weight lbs
481A24	Connection frame for SMART® interactive whiteboards	3,9	8,58
481A25	Projector frame for SMART® projectors	9,8	21,6
481A26	Handle bars for SMART® connection frame	2,8	6,16
481A17	Floor support for use with non-supporting walls	n.a.	n.a.
481A31	Mobile stand	n.a.	n.a.

All items sold separately

Whiteboard frame can also be used with 481A23: Universal projector frame for Hitachi, NEC and Epson projectors





Whiteboard frame for SMART® for the BalanceBox® 400H

Product Specifications 481A24 Connection frame for SMART® boards				Shipping dimensions				
	metric		US / imperial		metric		US / imperial	
	value	units	value	units	value	units	value	units
Length	1180	mm	46.5	inch	1360	mm	53.5	inch
Width	1458	mm	57.4	inch	125	mm	5	inch
Depth	144	mm	5.6	inch	55	mm	2.1	inch
Load capacity	95	kg	209	lbs	6,1	kg	13.4	lbs
Maximum screen size	120	inch						
Material	Sheet steel frame							
Finish	Powder coated in colour: Pantone Grey 18-0601 TPX							

Product Specifications 481A25 Frame for SMART® projectors				Shipping dimensions				
	metric		US / imperial		metric		US / imperial	
	value	units	value	units	value	units	value	units
Length	603	mm	23.75	inch	615	mm	24	inch
Width	413	mm	16.25	inch	430	mm	16.5	inch
Depth	43	mm	1.7	inch	50	mm	2	inch
Weight	9.8	Kg	21.6	lbs	9.8	kg	21.6	lbs
Material	Sheet steel frame							
Finish	Powder coated in colour: Pantone Grey 18-0601 TPX							

Product Specifications 481A26 Handle bars for SMART® connection frame				Shipping dimensions				
	metric		US / imperial		metric		US / imperial	
	value	units	value	units	value	units	value	units
Length	582	mm	22.9	inch	600	mm	23.1	inch
Width	551	mm	21.7	inch	560	mm	22	inch
Depth	22	mm	0.75	inch	30	mm	1.2	inch
Weight	2.8	kg	6.2	lbs	3	kg	6.6	lbs
Material	Tubular steel frame							
Finish	Powder coated in colour: Pantone Grey 18-0601 TPX							